

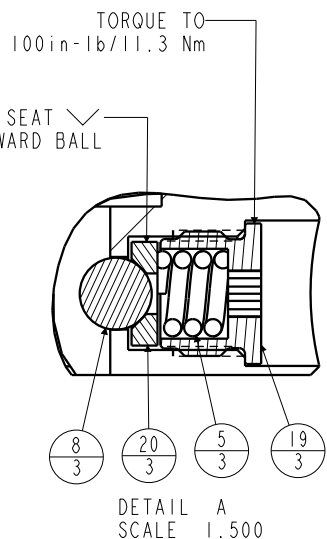

APPLY LUBRICANT TO ALL SEALS
PRIOR TO INSTALLATION.
DO NOT USE SILICONE TYPE LUBRICANTS.
FOR PROPER ARM MOUNTING SEE IS1505.



No.	QTY	PART No.	DESCRIPTION	Std. Seal Kit	FKM Seal Kit	Spring Kit
N/A	N/A	IS1505	INSTRUCTION SHEET, ARM INSTALLATION			
N/A	N/A	61704033	SPRING KIT			
N/A	N/A	6V711035	SEAL KIT, FKM			
N/A	N/A	60711035	SEAL KIT, STANDARD			
26	1	39V11051	WIPER, PRESS-IN, (1-1/2)	X	X	
25	1	39H52001	SEAL, U-CUP, 1-3/4 x 3/16 x 2-1/8	X	39V52001	
24	1	39H51002	O-RING, (-033)	X	39V51002	
23	1	81592121	CAM, SC, LP, 7500/33KN, RH, TC			
22	1	81592100	DISK, Ø1.00 X .19			X
21	1	81532111	PLUG, SC, LP, 7500/33KN, SA, TC			
20	3	81532108	SEAT, BALL, SC, LP, TC			
19	3	81532107	RETAINER, SC, LP, TC			
18	1	81532105	CAP, END, SC, LP, 33KN/7500			
17	1	81512110	PLUNGER, SC, LP, 7500/33KN, SA, TC			
16	1	49001905	BREATHER, 1/4 BSPP			
15	1	43068006	PLUG, 1/4 BSPP MALE			
14	1	39054018	BU RING, (-327)	X	X	
13	1	39054017	BU RING, (-033)	X	39054023	
12	1	39054016	BU RING, (1.5x.125x.063)	X	X	
11	2	39050042	O-RING, (-011)	X	39051025	
10	1	39011075	SEAL, LL, (1-1/2 X 1/8 X 1/8 1-3/4)	X	39V11075	
9	1	39001056	O-RING, (-119)	X	39V51014	X
8	3	23650004	BALL, TUNGSTEN-CARBIDE .250			
7	1	23600011	BALL, STEEL, ALLOY, .187			X
6	1	23350068	SPRING, COMPRESSION			X
5	3	23350066	SPRING, COMPRESSION			
4	10	21500304	SHCS, M6 X 1.0-6G X 20MM			
3	2	21500200	WASHER			
2	3	21500031	SHCS, M5 X 0.8 X 14, ALY			
1	2	21500019	SCREW, CAP, BTNH, M3 X 6, ALY			

PARTS LIST



VEKTEK, INC.
1334 E. SIXTH AVE. P.O. BOX 625
EMPORIA, KS. 66801 U.S.A.

<p>ASSEMBLIES AFFECTED</p> <p>41463311</p> <p>41463311F</p>	<p>PARTS LIST, ASSY, SC, LP, TC, TF, 33KN, SA, RH</p> <p>SIZE A MPL7151</p> <p>REV D</p>
---	--

FORM FEG035_PL.A.SIZE, REV. B

D	5922	RELEASE	JDW	03/23/26
REV	IN ACCORDANCE WITH ECN	EFFECTIVE DATE	REVISED BY	DATE
DRW BY:	DATE: 6-7-11	DRAWING STATUS: Released		
PRODUCTION APPROVED FOR RELEASED STATUS ONLY				

